



**ALARIS**  
KUHNE

INSPIRING THE NEXT RF SOLUTION

+49 (0) 9293 - 800 640  
sales@kuhne.alaris.tech  
www.kuhne.alaris.tech  
Scheibenacker 3, 95180 Berg,  
Germany

Version 1.0

# KU LNC 8595 C PRO2



## Manual

Directors: Ian Duke/Gustav Wenhold  
Reg no: HRB 3350 Hof, VAT-ID-No: DE 813343044, WEEEReg.-Nr. DE34186665

Kuhne electronic GmbH  
Scheibenacker 3, 95180 Berg  
Germany

A DIVISION OF

**ALARIS**  
THE RF TECHNOLOGY GROUP





## Specifications (Ta = 25 °C):

### Type

### KU LNC 8595 C PRO2

Frequency range (RF)  
Noise figure @ 18 °C  
Gain (switchable)

8500 ... 9500 MHz  
typ. 1.0 dB, max. 1.2 dB  
min. 47 dB, typ. 50 dB (high gain mode)  
min. 35 dB, typ. 37 dB (low gain mode)  
+/- 2.5 dB  
min. +20 dBm (high gain), min. +10 dBm (low gain)  
min. 10 dBm

Gain ripple  
Output IP3  
P1dB

### Output frequency (RF in)

@ LO 8130 MHz  
@ LO 8440 MHz  
@ LO 9700 MHz  
@ LO 9900 MHz  
LO accuracy @ 18 °C  
LO frequency stability (0 ... 40 °C)

IF = 470 ... 1170 MHz	(RF = 8600 ... 9300 MHz)
IF = 260 ... 960 MHz	(RF = 8700 ... 9400 MHz)
IF = 700 ... 200 MHz	(RF = 9000 ... 9500 MHz)
IF = 770 ... 150 MHz	(RF = 9130 ... 9750 MHz)
+/- 1 kHz	
+/- 0.5 ppm	

### Phase noise @ 8130 MHz

@ 1 kHz  
@ 10 kHz  
@ 100 kHz

typ. -90 dBc/Hz  
typ. -94 dBc/Hz  
typ. -102 dBc/Hz

### Operating parameters

Supply voltage  
Current consumption  
Power consumption

+9 ... 36 V DC  
typ. 250 mA @ 12V (IF amplifier enabled)  
typ. 3.0 W

### Mechanics

Input connector / impedance  
Output connector / impedance  
Case  
Dimensions (mm)  
Weight

SMA-female, 50 ohms  
SMA-female, 50 ohms  
milled aluminium, IP43  
82 x 64 x 22  
typ. 230 g

### Absolute ratings

Maximum RF input power  
Operating case temperature range

1 mW (0 dBm)  
-20 ... +55 °C

### Features

- Low noise figure
- Large bandwidth
- Low phase noise oscillator
- High frequency stability of the oscillator due to 10 MHz reference input
- High linearity
- Antenna port protected against static discharge
- Small and light-weight to allow easy pole mounting
- Tri-colour LED indicates unit status and gain mode setting
- Overvoltage protection and reverse polarity protection
- Remote power supply via output connector (for example KU BT 10 REF)

### Applications

- Deep Space Communications
- Analog and digital transmission systems

### Recommended Pre-Amplification

- KU LNA 700900 A WG

Please note: The total gain of pre-amplifier + attenuator + converter should not exceed 60 dB. More information on page 7.

### CE Konformität / CE Conformity

EMC directive 2014/30/EU  
Low voltage directive 2014/35/EU  
RoHS directive 2011/65/EU





## Dimensions / Mounting holes

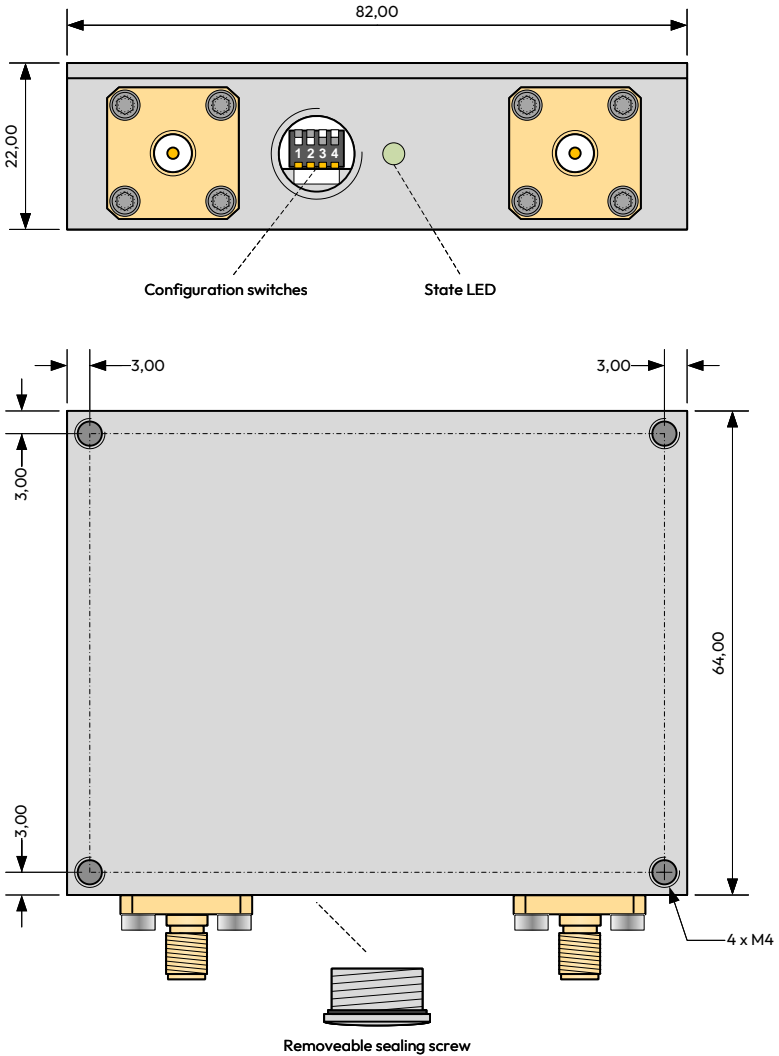



## Configuration Switches / LED state

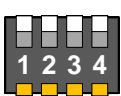

OFF  
ON

**Switch 1 + 2** - (Local oscillator frequency)

**Switch 3** - (Gain)

**Switch 4** - (User local oscillator frequency)

**Device Error**

**LED state**  
Red

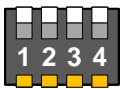

OFF  
ON

**Switch 1 - OFF**  
**Switch 2 - ON**  
LO 8130 MHz  
IF 470 ... 1170 MHz

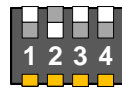

OFF  
ON

**Switch 1 - OFF**  
**Switch 2 - ON**  
LO 9700 MHz  
IF 700 ... 200 MHz

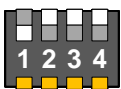

OFF  
ON

**Switch 1 - ON**  
**Switch 2 - OFF**  
LO 8440 MHz  
IF 260 ... 960 MHz

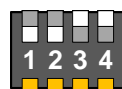

OFF  
ON

**Switch 1 - ON**  
**Switch 2 - ON**  
LO 9900 MHz  
IF 770 ... 150 MHz

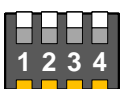

OFF  
ON

**Switch 3 - OFF**  
Low Gain



**LED state**  
Green

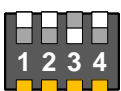

OFF  
ON

**Switch 3 - ON**  
High Gain



**LED state**  
Blue

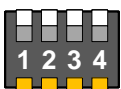

OFF  
ON

**Switch 4 - OFF**

Local oscillator configuration with Switch 1+2

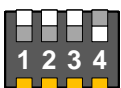

OFF  
ON

**Switch 4 - ON**

Local oscillator configuration with Switch 1 + 2 disabled  
User defined local oscillator frequency is enabled

In the case that **Switch 4** is in position **ON** the user defined local oscillator frequency is activated. This user defined local oscillator frequency can be selected in the range from 8000 ... 8500 MHz and from 9500 ... 9990 MHz. The frequency step size of the oscillator frequency is 10 MHz. The user defined oscillator frequency can be programmed with a special programming cable.

For example the oscillator frequency can be chosen to 8310 MHz or 9870 MHz .

## Optional Connector PCB

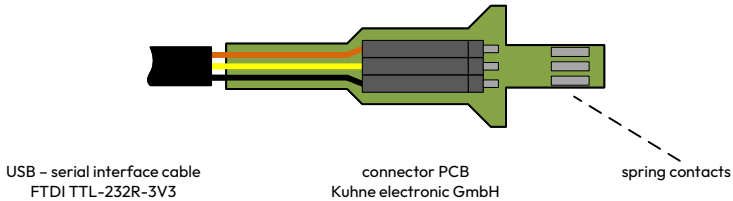

### Configure the user defined local oscillator frequency

- connect the USB - serial interface cable with your PC
- start a terminal program on your PC (for example „hterm“)
- choose the COM port of the USB - serial interface cable

```
BAUDRATE 9600
DATABITS 8
STOPBITS 1
NO FLOW CONTROL
```

- insert the connector PCB with connected USB - serial interface cable into the configuration slot the spring contact must show to the top cover of the down converter
- power up the down converter
- send „s“ with the terminal program to the converter to get the state of the converter

```
Kuhne electronic GmbH - KU LNC 8595 C PRO2

PLL locked
GAIN high
Selected LO frequency: 8130 MHz
User defined LO frequency: 8400 MHz
User defined LO frequency enabled
```

- send „8400LO“ with the terminal program to the converter to get set the user defined oscillator frequency to 8400 MHz
- power down the down converter
- remove the connector PCB

## Mounting instructions

All LNCs from Kuhne electronic GmbH are labelled with at least protection class IP41 in accordance with DIN EN 60529, **unless a higher protection class is explicitly indicated in the valid specifications for the protection class on page 2.**

This provides information on the resistance of the unit against unwanted penetration of foreign bodies or moisture into the interior of the unit according to the following provision:

- Protected against granular solid foreign bodies (diameter  $\geq 1$  mm).
- Protection against falling spray up to  $60^\circ$  from vertical

The LNC modules have been designed with maximum protection against moisture. Nevertheless, water may enter the unit due to the design of the RF connectors, which is why some special features should be taken into account during installation.

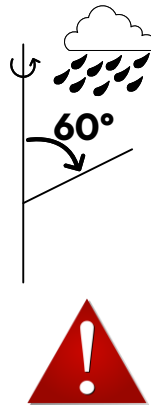
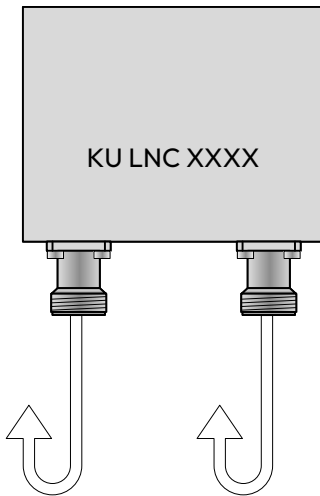

**Mounting with the RF connectors vertically downwards**

**If possible, do not use cable connections with angled elbow connectors, but lead plugs out with a straight cable and a loop pointing downwards.**

In the event of improper installation or handling that does not comply with our recommendations, Kuhne electronic reserves the right to exclude the warranty claim.



## Application diagram

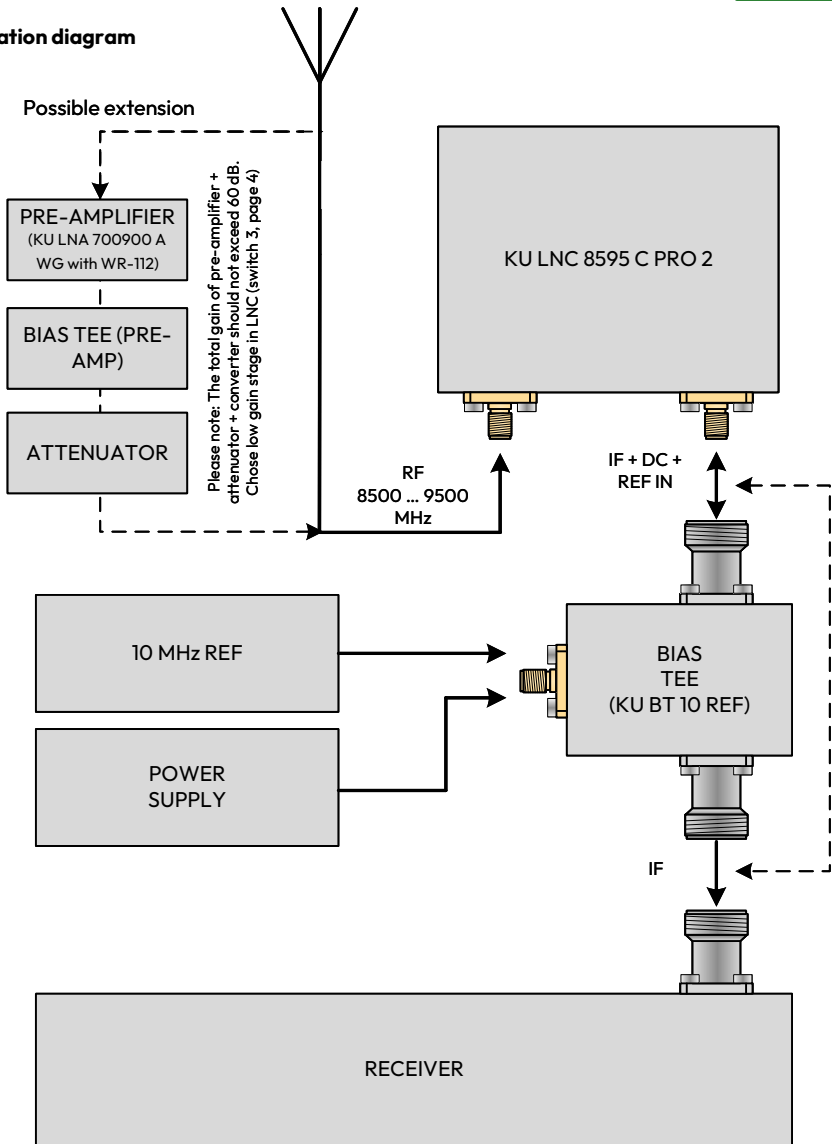

## 10 MHz reference input, Typical performance

An external 10 MHz reference frequency can be connected to the down converter to achieve highest frequency accuracy. When an external 10 MHz source is connected to the down converter, the internal reference oscillator automatically will be deactivated. Then, the frequency stability depends only on the reference frequency. The frequency of 10 MHz can be supplied by a highly stable OCXO, a reference oscillator of a frequency counter, a rubidium frequency standard or a GPS controlled frequency source. The output power range of the external reference source must be in the range from 2 to 10 mW on a 50 ohms load. If no 10 MHz reference frequency is available the down converter unit works with the frequency stability of the built-in TCXO. The reference frequency signal must be sine wave with low harmonics level. The reference frequency signal and its harmonics are on the IF cable and can be received from the receiver.

Recommended phase noise performance of the reference frequency source.

- 70 dBc/Hz @ 1 Hz
- 100 dBc/Hz @ 10 Hz
- 125 dBc/Hz @ 100 Hz
- 140 dBc/Hz @ 1 kHz
- 150 dBc/Hz @ 10 kHz
- 155 dBc/Hz @ 100 kHz

## Typical phase noise at 8130 MHz local oscillator frequency (+ ext. 10 MHz):

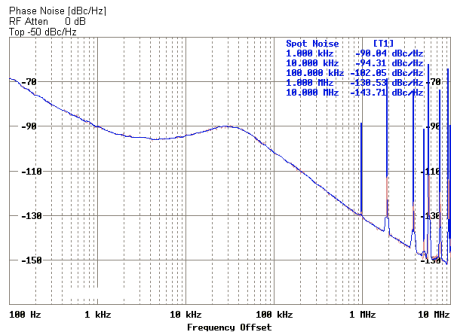

## Typical gain and noise figure (8130 MHz local oscillator frequency):

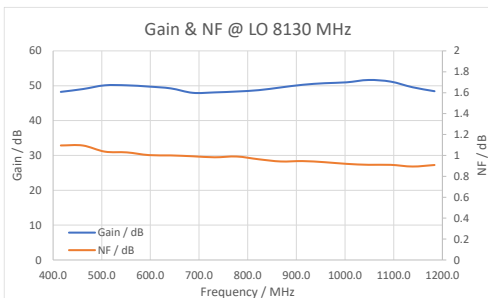

## Typical gain and noise figure (8440 MHz local oscillator frequency):

